

CJSS

彈簧式蓄能器

CJSS SPRING ACCUMULATOR



產品特性

透過彈簧式蓄能器吸收壓力變動，防止因異常高壓或低壓而導致系統壓力變化。

FEATURES

Accumulator absorbs the pressure fluctuation so that it prevents system pressure from variation due to the high or low abnormal pressure.

選配項 OPTIONS

分類	基準使用壓力
	CLASSIFICATION
低壓彈簧式蓄能器 Spring Accumulator for Low Pressure	2/3/4/ Mpa

訂購標示法 ORDERING INDICATION

示例: CJSS-402HSB

CJSS	系列 Series	CJSS
4	基準使用壓力 Standard Operating Pressure	2 : 2.0MPa 3 : 3.0MPa 4 : 4.0MPa
02	排出油量 Amount of Discharge Oil	02 : 2.5cm ³ 05 : 5.0cm ³ 10 : 10.0cm ³
H	安裝方向 Mounting Direction	H: 橫向安裝 H : Horizontal Mounting  V: 縱向安裝 V : Vertical Mounting 
S	配管方式 Piping Method	C : 外配管型 (G螺紋) Piping Option (BSPP Thread (G-Thread)) S : 外配管型 (Rc螺紋) Piping Option (BSPT (Rc-Thread)) G : 板式連接型 Gasket Option GC : 板式+外配管型 (G螺紋) 型 Gasket + Piping Option (BSPP Thread (G-Thread)) GS : 板式+外配管型 (Rc螺紋) 型 Gasket + Piping Option (BSPT (Rc-Thread))
B	配管方向(H: 僅限橫向安裝且為外配管型: C/S/GC/GS 的情況下) Piping Direction Selected for both H: Horizontal Mounting and Piping Method: C/S/GC/GS	A : 上面配管 A : Top Piping  B : 側面配管 B : Side Piping  ※ V: 選擇縱向安裝時, 即為「無標記」。 ※ For V: Vertical Mounting, Piping Direction is [Blank]. ※ H: 橫向安裝且為外配管型: 選擇G時, 即為「無標記」。 ※ For H: Horizontal Mounting and Piping Method: G, Piping Direction is [Blank].

特性曲線圖的解讀方法

通過彈簧式蓄能器吸收壓力變動，以防止因異常高壓或低壓而導致系統壓力變化。

使用油缸	配管	閥類的容積	溫度變化量	使用壓力	熱膨脹係數
Clamp Used	Piping	Valve Capacity	Temperature Change : ΔT	Operating Pressure : P	Thermal Expansion Coefficient : α
CHA-55×4 台 (1 台油缸夾緊時的油缸容量 : 26.7cm ³)	內徑φ6×2m (1m 的配管容積 : 28.3cm ³)	20cm ³	-20°C	4.0MPa	8×10 ⁻⁴

選型方法

- 夾具迴路容積 (V) 的計算
油缸容積 + 配管容積 + 閥類的容積
 $V = (26.7 \times 4) + (28.3 \times 2) + 20 = 183.4 \text{ cm}^3$
- 變化容積 (ΔV) 的計算
夾具迴路容量 (V) × 熱膨脹係數 (α) × 溫度變化量 (ΔT)
 $\Delta V = 183.4 \times (8 \times 10^{-4}) \times (-20) = -2.93 \text{ cm}^3$
- 蓄能器型號的選定
根據使用壓力 (P)= 4.0MPa, 選定 CJSS4000
根據變化容積 (ΔV)= -2.93cm³, 選定 CJSS405 (變化容積超出曲線所示範圍時, 請考慮容積大的「CJSS410」彈簧式蓄能器。)
- 彈簧式蓄能器特性的確認 (請通過右圖進行確認。)
溫度變化 (-20°C) 後的壓力 : 2.92MPa
殘餘吐出容積的剩餘值 : 2.07cm³
- 請選定安裝方向、配管口、配管方向。

注意事項

- 請考慮彈簧力的固有差異，在選擇油容積時留有餘量。
【餘量油量的標準: CJSS02...0.5cm³、CJSS05...1.0cm³、CJSS10...1.5cm³】

規格參數表 SPECIFICATION

型號	基準使用壓力	耐壓	吐出油量	吸入油量	壓縮係數 (β) ※1	重量	使用溫度	使用流體
MODEL	STANDARD OPERATING PRESSURE (Mpa)	WITHSTANDING PRESSURE (Mpa)	DISCHARGE OIL CAPACITY (cm ³)	ABSORBING CAPACITY (cm ³)	Compression Factor(β) ※1 (Mpa/cm ³)	WEIGHT(kg)	OPERATING TEMPERATURE(°C)	USABLE FLUID
CJSS-202	2.0	14.0	2.5	1.0	0.40	0.8	0~70	相當於ISO黏度等級的 ISO-VG-32一般液壓油 General Hydraulic Oil Equivalent to ISO-VG-32
CJSS-205	2.0	14.0	5.0	2.0	0.31	1.0	0~70	
CJSS-210	2.0	14.0	10.0	4.0	0.16	1.7	0~70	
CJSS-302	3.0	14.0	2.5	1.0	0.40	0.8	0~70	
CJSS-305	3.0	14.0	5.0	2.0	0.33	1.1	0~70	
CJSS-310	3.0	14.0	10.0	4.0	0.17	1.7	0~70	
CJSS-402	4.0	14.0	2.5	1.0	0.49	0.8	0~70	
CJSS-405	4.0	14.0	5.0	2.0	0.37	1.1	0~70	
CJSS-410	4.0	14.0	10.0	4.0	0.18	2.0	0~70	

HOW TO READ THE CHARACTERISTIC DIAGRAM

Accumulator absorbs the pressure fluctuation so that it prevents system pressure from variation due to the high or low abnormal pressure.

SELECTION METHOD

- Calculate Fixture Circuit Capacity (V)
Clamp Capacity + Pipe Capacity + Valve Capacity
 $V = (26.7 \times 4) + (28.3 \times 2) + 20 = 183.4 \text{ cm}^3$
- Calculate Change in Capacity (ΔV)
Fixture Circuit Capacity (V) x Thermal Expansion Coefficient (α) x Amount of Temperature Change (ΔT) , $\Delta V = 183.4 \times (8 \times 10^{-4}) \times (-20) = -2.93 \text{ cm}^3$
- Select Accumulator Mode
Operating Pressure (P)= 4.0MPa select CJSS4000
Change in Capacity (ΔV)= -2.93cm³ select CJSS4050. (If the required discharge capacity is greater than showed on the graph, select larger accumulator [e.g. CJSS4100].)
- Check the Accumulator Characteristics (Graph on the right)
Pressure after Temperature Change (-20°C) : 2.92MPa
Residual Oil Discharge Margin : 2.07cm³
- Select the Attachment and Piping Methods.

NOTE

- When marking your selection, calculate tolerance for the oil capacity taking the spring force deviation into consideration.
【Approximate amount of spare oil : CJSS02...0.5cm³、CJSS05...1.0cm³、CJSS10...1.5cm³】

外形尺寸 EXTERNAL DIMENSIONS

CJSS□02-H□□ CJSS□05-H□□

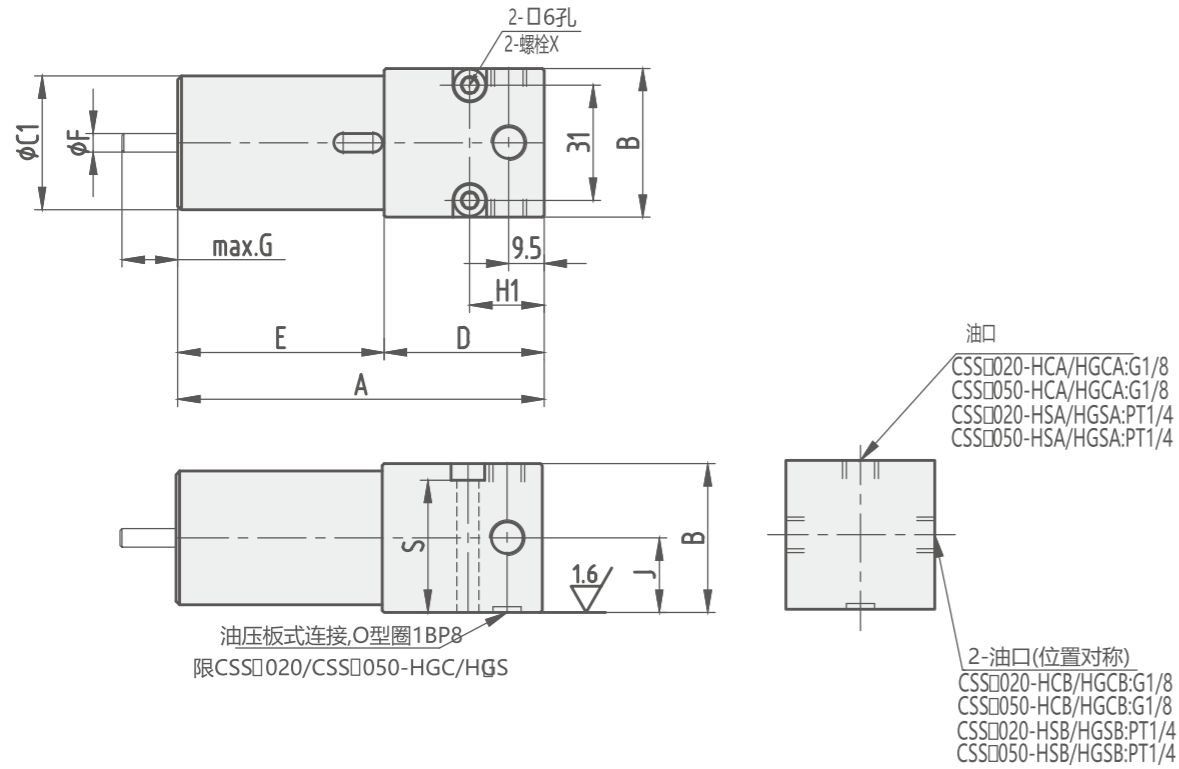

CJSS□10-H□□

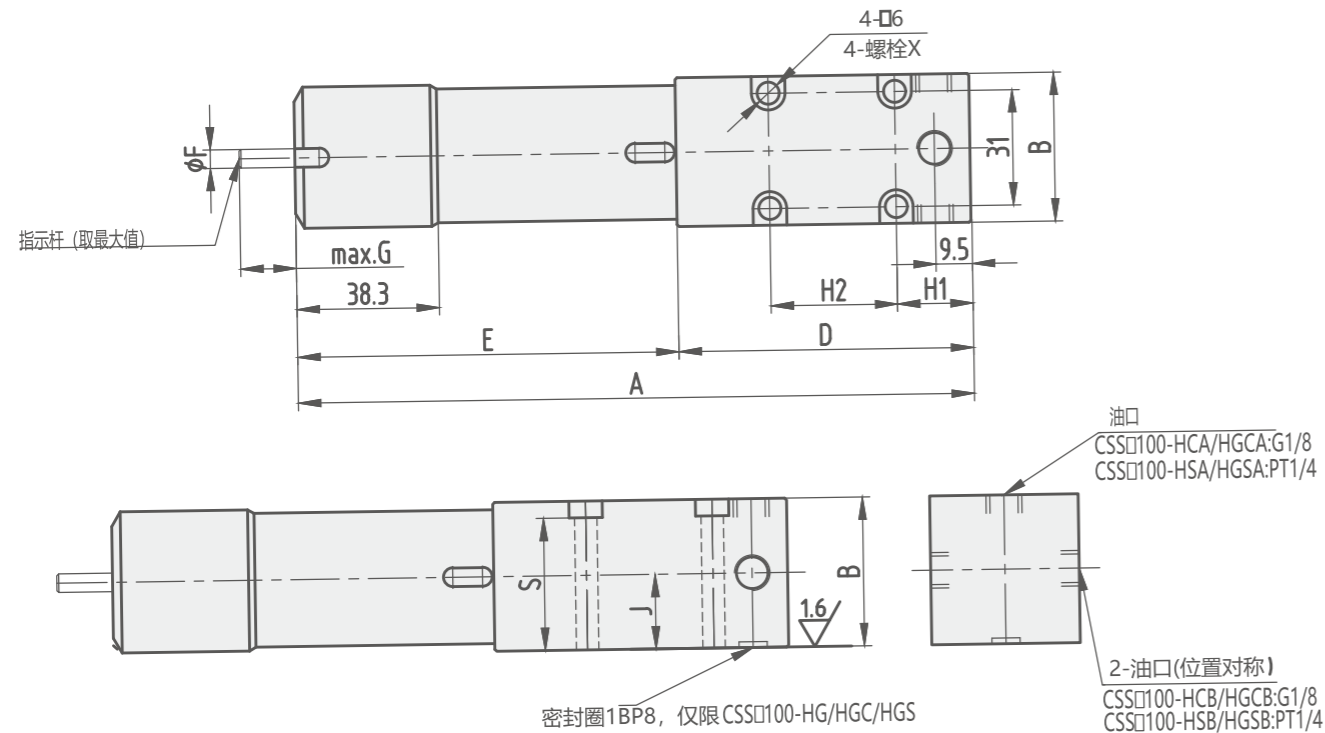

安裝部位加工尺寸 MACHINING DIMENSIONS OF MOUNTING AREA

CJSS□02-V□

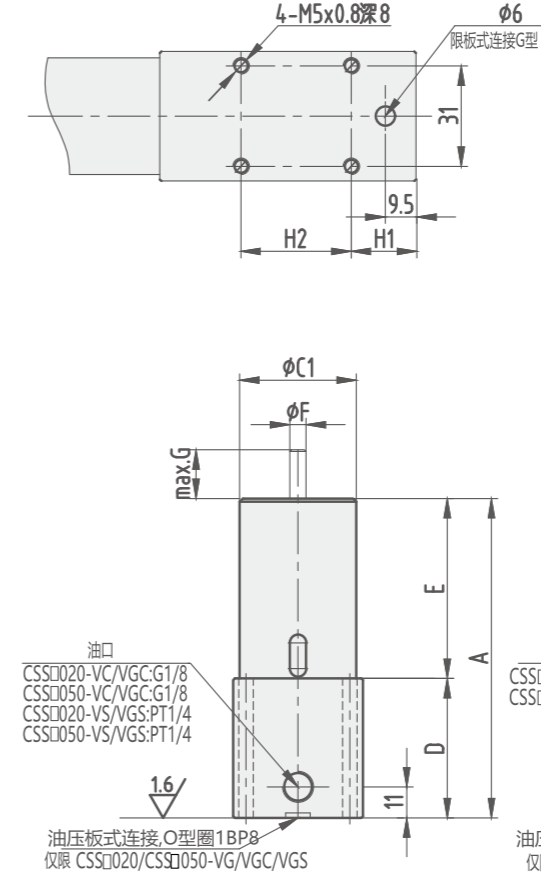

CJSS□10-V□

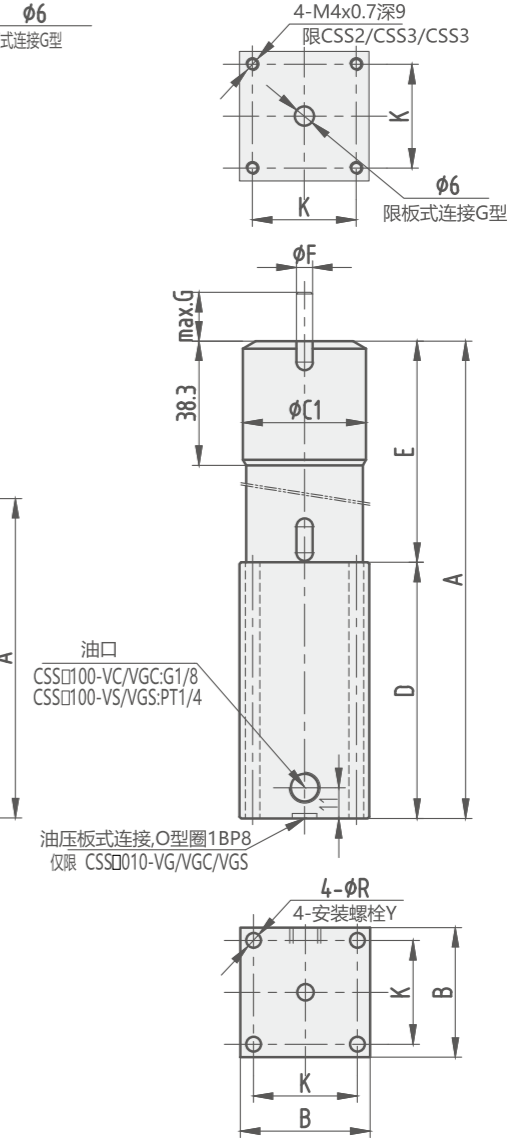

Unit:mm

MODEL	A	B	C1	C2	D	E	F	G ^{※1}	H1	H2	J	K	R	S	安裝螺栓 X Mounting Bolt X	安裝螺栓 Y Mounting Bolt Y
CJSS202 CJSS302 CJSS402	98.5	40	36	—	43	55.5	5	15	20	—	20	32	4.5	34	M5×0.8×40	M4×0.7×50
CJSS205 CJSS305 CJSS405	136.5	40	36	—	55	81.5	5	27	20	—	20	32	4.5	34	M5×0.8×40	M4×0.7×60
CJSS210 CJSS310 CJSS410	241.5	40	38	36	79	162.5	5	49	20	34	20	32	4.5	34	M5×0.8×40	M4×0.7×85

注意事项

- ※1. 指示器會隨壓力變化而頂出。計劃空間布置時需要考慮指示器的最大頂出量，以避免與其他部位的干涉。
 - ※2. G (板式连接型) 的安裝面 (O 形密封圈密封面) 的表面粗糙度應按 6.3S 加工。
1. 請勿擅自對本產品進行解體。機器設備內置有彈簧，擅自拆卸往往會導致零部件彈出，非常危險。

NOTE

- ※1. Indicator extends proportionally to pressure. Be aware not to interfere with other devices of max. extension dimension when designing.
 - ※2. Roughness of mounting surface (O ring seal surface) should be 6.3S or better.
1. Do not disassemble. Components include pressured spring parts. It is dangerous to disassemble.